

Stationary-C-Welding-Gun

Series MC 296

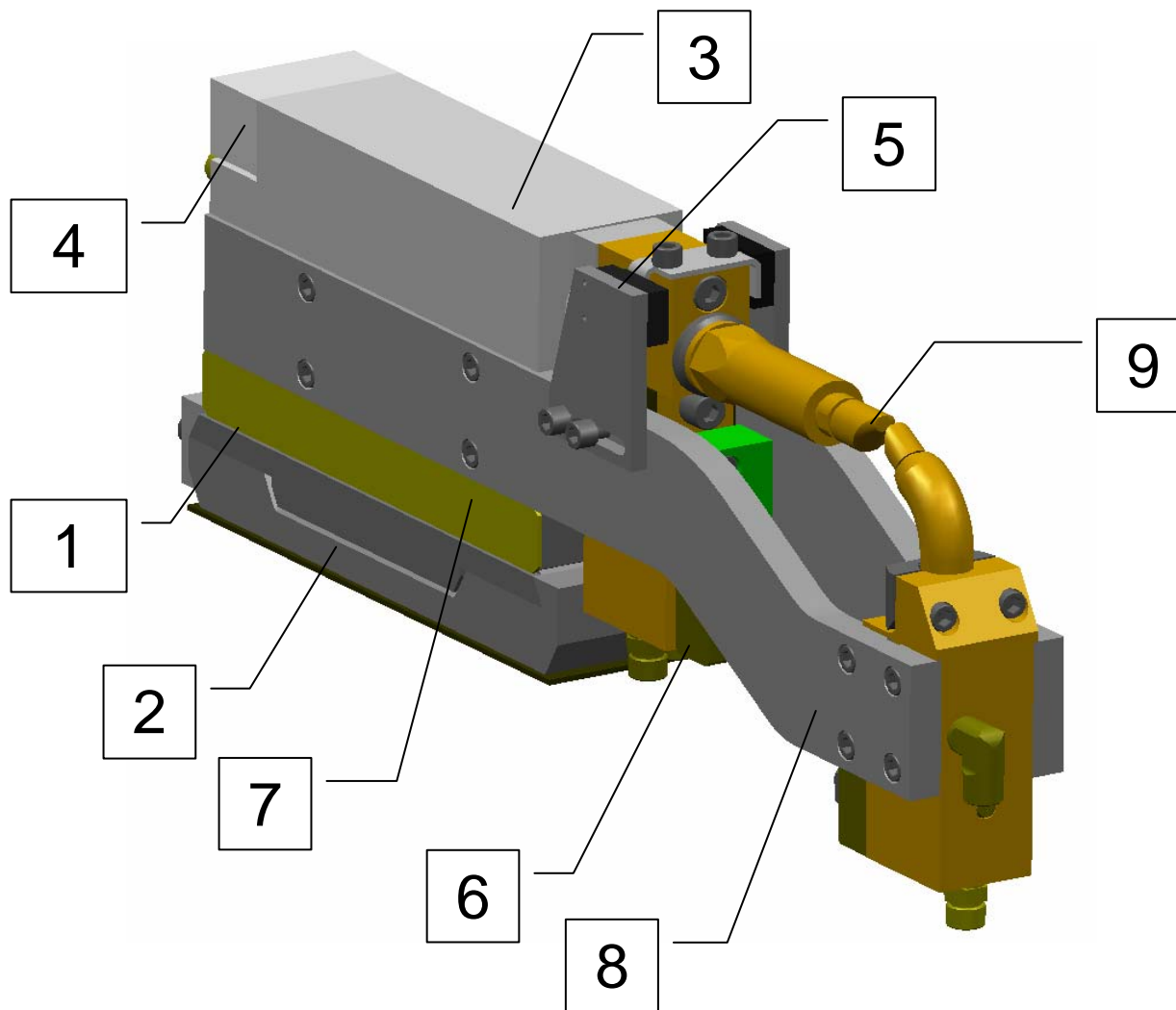

- 1 Basic Unit
- 2 Flange acc. to customers requirement
- 3 Cylinder
 Ø44 - 2 or 3cycles
 Ø58 2 or 3cycles
 Ø70 - 2 or 3cycles
 Ø80 2 or 3cycles
 Working stroke 36 – 50 – 80 – 100 - 130mm
- 4 Absorber Unit
- 5 Position monitoring
- 6 Current connection
 Secondary cable up to 600 mm² or
 Watercooled cable up to 250 mm²
- 7 Equalizer
 Spring or pneumatic
- 8 Gun arms
 Layout acc. to welding task
 Mat.: CuCrZr – CuZn40Pb2 – G-CuCr – VA
- 9 Electrode caps and shanks
 acc. to welding task